



ELITE
DOORS & WINDOWS

ELITEDOORSWINDOWS.COM

fineline

Filigrane Fenster, Türen und
Trennwände aus Stahl

Filigree windows, doors and
partitions made of steel





Die Freiheit der Architektur

Freedom of architecture

Unser Anspruch ist höchste Qualität. Seit mehr als 60 Jahren entwickeln und produzieren wir Stahlsysteme für Fenster, Türen und Fassaden – mit handwerklichem Geschick und einer Menge Know-how. Bei unseren Produktlösungen setzen wir auf den vielseitigen Werkstoff Stahl und verbinden auf diese Weise ansprechende Ästhetik mit höchster Belastbarkeit. Sowohl Planer als auch Metallbauer profitieren von unserer jahrzehntelangen Erfahrung – und erhalten neben überzeugender Qualität einen maximalen gestalterischen Freiraum. Oder wie wir es nennen:

Die Freiheit der Architektur.

Our goal is top quality. We have been developing and producing steel systems for windows, doors and facades for more than 60 years - with craftsmanship and a great deal of know-how. In our product solutions we rely on the versatile material steel and in this way combine appealing aesthetics with maximum resilience. Both planners and metal manufacturers benefit from our decades of experience - and, in addition to convincing quality, are given a maximum in design freedom. Or as we call it:

Freedom of architecture.



100% Fortschritt Improvement





fineline –
entwickelt nach modernsten Standards

Gestalten Sie mit rp fineline einzigartige Lebensräume und kreieren Sie ein authentisches, historisch nachempfundenenes Ambiente, gepaart mit zeitloser Eleganz und Langlebigkeit.

Erleben Sie den urbanen Charme von Loft-Wohnungen und empfinden Sie den historischen Industriecharakter nach. Realisieren Sie den modernen Bauhaus-Stil oder erwecken Sie die klassische Eleganz von historischen Gebäuden zu neuem Leben. Die feingliedrigen und schmalen Stahlprofile eignen sich ideal für den Einsatz in denkmalgeschützten Gebäuden oder in Häusern mit erhaltenswerter Bausubstanz. Verwirklichen Sie Ihre eigenen Ideen – rp fineline bietet Ihnen die Möglichkeit, individuelle Wohnatmosphären zu gestalten.

fineline –
developed according to the latest standards

Use rp fineline to design unique living spaces and create an authentic, historically influenced ambience, paired with timeless elegance and longevity.

Experience the urban charm of loft apartments and recreate their historical industrial character. Create a modern take on Bauhaus style or revive the classic elegance of historical buildings. The slender and narrow steel profiles are ideally suited for use in listed buildings or in houses that are worth preserving. Bring your own ideas to life – rp fineline makes it possible for you to fashion your own unique living environments.





Gefühl für eine behutsame
Adaptierung historischer
Werte: Von der Gründerzeitvilla
bis zum Industriekomplex.

A feeling for the meticulous
adaptation of historical quality:
from Wilhelminian-style villas
to industrial complexes.

100%
Vielfalt
Versatility





Wer „Loft“ sagt, muss auch
„RP Technik“ sagen.

When you think “loft”,
think “US”.

100%
großzügig
generous



fineline





100% Qualität Quality

fineline – ermöglicht die
Synthese von Kunst und
Handwerk von Klassik bis
Bauhaus.

fineline – brings together
art and craft, from classical
to Bauhaus styles.



fineline





100%
elegant
sophisticated





O

Zeitlose, klassische
Eleganz, die im
Gedächtnis bleibt.

Timeless, classical
elegance – forever
unforgettable.



Ihre Vorteile im Fokus



Schmalste Profile vereint mit ausgezeichneten Wärmedämmeigenschaften

DESIGN

Die unendliche Vielseitigkeit von Stahl ermöglicht den Einsatz sowohl in traditioneller als auch in zeitgenössischer Architektur – im Außenbereich oder im Inneren des Gebäudes.

GESTALTUNGSFREIHEIT

Erfahren Sie nahezu grenzenlose Freiheit für Ihre Ideen. In der Gestaltung erlaubt das Material Stahl größtmögliche Spannweiten bei idealen statischen Werten. Die Gesamtästhetik wird durch passgenaues Zubehör wie Schlosskästen, Schwellen und Griffe abgerundet – ein System aus einem Guss!

TRANSPARENZ

Extrem schlanke Stahlprofile mit minimalen Ansichtsbreiten schaffen Transparenz, kreieren somit eine lichtdurchflutete Wohnatmosphäre und sorgen nebenbei für ein angenehmes Raumklima.

NACHHALTIGKEIT

Stahl als Werkstoff überzeugt durch seine lange Haltbarkeit über Jahrzehnte hinweg, die vielen anderen Materialien deutlich überlegen ist. Gleichzeitig ermöglicht Stahl dank der guten statischen Eigenschaften einen reduzierten Materialeinsatz und kann nach der Nutzung verlustfrei recycelt werden.





Advantages in focus

The narrowest profiles with excellent thermal insulation properties

DESIGN

The endless versatility of steel allows it to be used in both traditional and contemporary architecture – outside or inside the building.

DESIGN FREEDOM

Experience almost limitless freedom for your ideas. In terms of design, the material steel allows the largest possible spans with ideal static values. The overall aesthetics are rounded off by custom-fit accessories such as lock cases, thresholds and handles – a homogenous system.

TRANSPARENCY

Extremely slim steel profiles with minimal face widths create transparency, thus generating a light-flooded living environment and also ensuring pleasant ambient conditions.

SUSTAINABILITY

Steel as a material impresses with its long durability over decades, which is clearly superior to many other materials. At the same time, steel enables reduced material use thanks to its good static properties and can be recycled without loss after use.

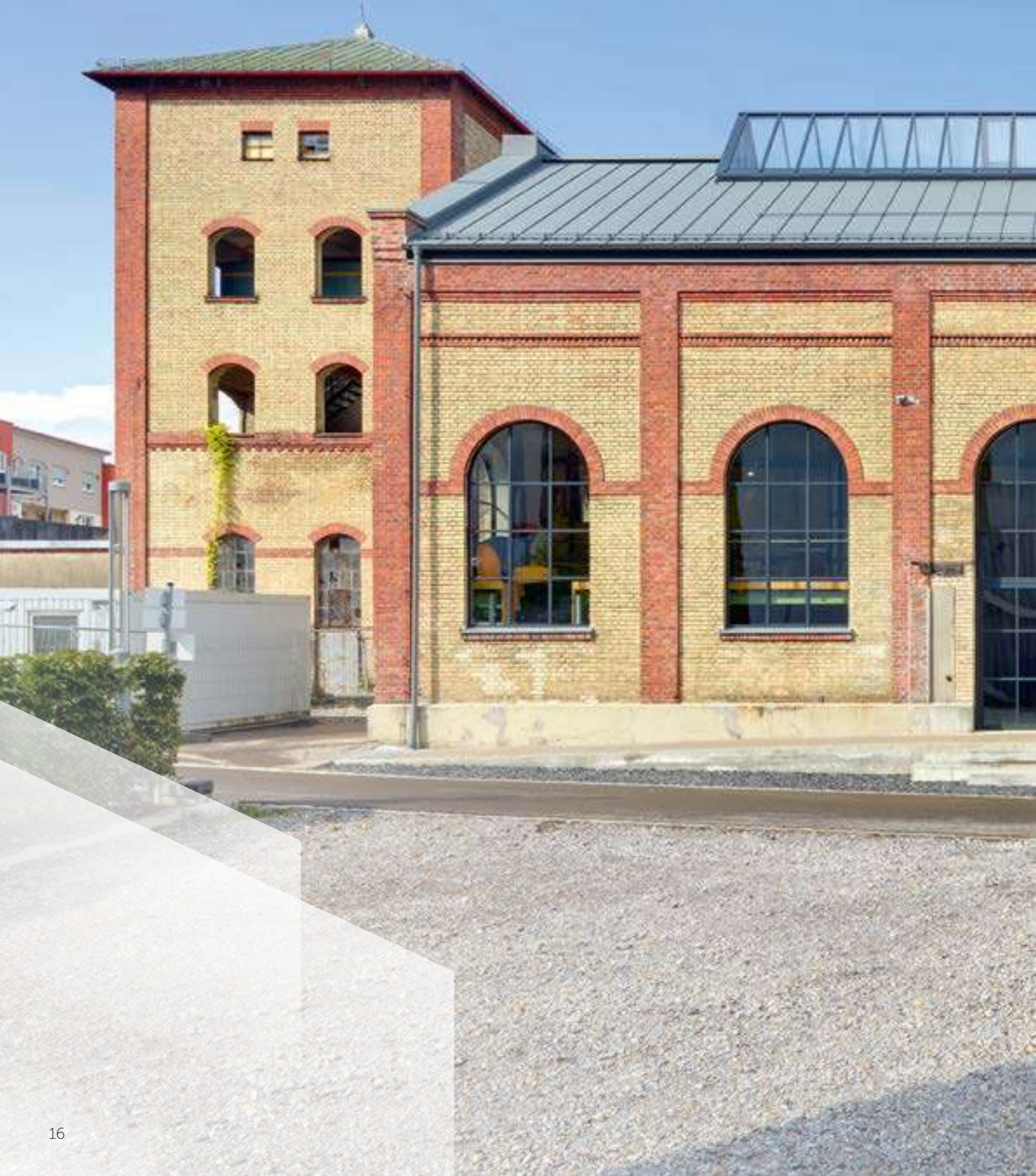



100%
Flexibilität
Flexibility

O E

O





Individualität ist Trumpf: Fünf verschiedene Glasleisten bieten eine hohe Flexibilität bei der Gestaltung – wie die schräge, dem Look eines mit Kitt verglasten Fensters nachempfundene, Variante. Gerade bei denkmalgeschützten Gebäuden lässt sich so eine authentische, historische Optik erreichen. Mit den eingeschwenkten L-förmigen Glasleisten der fineline 70 ohne sichtbare Verschraubung kann ein stark reduziertes Design realisiert werden. Drei quadratische Geometrien, welche die Flügeldetails klassisch flächenbündig, mit einem Flächenversatz oder einer Kontur akzentuieren, runden die breite Auswahl optimal ab.

Individuality is the key: Five different glazing beads offer a high degree of flexibility in the design – such as the inclined version that mimics the look of a putty-glazed window. An authentic, historic look can be achieved in this way, especially in listed buildings. The swivelled-in L-shaped glazing beads of the fineline 70 without visible screw connections enable a greatly reduced design to be achieved. Three square geometries, which accentuate the sash details – classically flush with the surface, with a surface offset or a contour – optimally round off the wide selection.



Glasleiste Standard
Standard
glazing bead



Glasleiste Versatz
Offset
glazing bead



Glasleiste Schräg
Inclined
glazing bead



Glasleiste Winkel
Angled
glazing bead



Glasleiste Kontur
Contoured
glazing bead

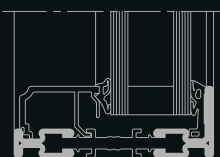



Wählen Sie aus drei verschiedenen Design-Varianten zur Integration des Schlosskastens in die Tür: Gradlinig eingefasst in horizontale oder vertikale Sprossen – oder eine besonders reduzierte Variante ohne Sprossen nur mit einem Glasausschnitt.

Choose from three different design options for the integration of the lock case into the door: Enclosed by either transoms or a mullion – or left without transoms or mullions with a simple glass cut-out for a particularly minimalistic look.

100%
Spielraum
Scope



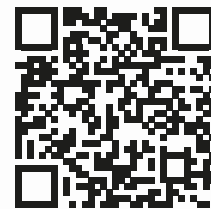



45 mm





70D

100%
filigran
filigree

Schmäler als eine Kreditkarte! Mit fineline 70D steht ein schmales, thermisch getrenntes Stahltür-System mit Gesamtansichtsbreiten von nur 45 mm (Flügel/Rahmenkombination) für den hochwertigen Wohnungsbau und die Renovierung denkmalgeschützter Gebäude zur Verfügung.

Slimmer than a credit card! fineline 70D provides a slender, thermally separated steel door system with total sightlines of just 45 mm (sash/frame combination) for high-quality residential construction and the renovation of listed buildings.



D





100% griffig in hand

Alles im Griff! Die Fenstergriffe und Türdrücker für fineline lassen keine Wünsche offen. Aktuelle Designlinien mit puristischer Optik in Stahl, Edelstahl oder Aluminium gehen eine perfekte Symbiose mit den filigranen Profilen ein. Aufliegende Beschläge mit klassischen oder verspielt nostalgischen Formen greifen die Stilelemente historischer Bauwerke gekonnt auf und eignen sich bestens für die Renovierung.

Everything under control. The window and door handles for fineline leave nothing to be desired. Current design lines with a purist look in steel, stainless steel or aluminium form a perfect symbiosis with the filigree profiles. On the other hand, overlaying fittings with classic or playfully nostalgic forms skilfully take up the stylistic elements of historical buildings and are ideally suited for renovation.

fineline 70



Fenstergriffe für verdeckt liegende Beschläge
Window handles for concealed fittings

Josh



Edelstahl matt
Stainless steel
RF1931042



Schwarz matt
Black matte
RF1931044



Aluminium
RF1931040

abschließbar / lockable



Edelstahl matt
Stainless steel
RF1931043



Schwarz matt
Black matte
RF1931045



Aluminium
RF1931041

Bern



Edelstahl matt
Stainless steel
RF1931022



Schwarz matt
Black matte
RF1931024



Aluminium
RF1931020

abschließbar / lockable



Edelstahl matt
Stainless steel
RF1931023



Schwarz matt
Black matte
RF1931025



Aluminium
RF1931021

Highland



Edelstahl matt
Stainless steel
RF1931032



Schwarz matt
Black matte
RF1931034



Aluminium
RF1931030

abschließbar / lockable



Edelstahl matt
Stainless steel
RF1931033



Schwarz matt
Black matte
RF1931035



Aluminium
RF1931031

Essential Line

abschließbar / lockable

Auch als Türdrücker erhältlich:
Also available as door handles::



Edelstahl matt
Stainless steel
RF1931036



Edelstahl matt
Stainless steel
RF1931037



Edelstahl matt
Stainless steel
RF2431038



Josh

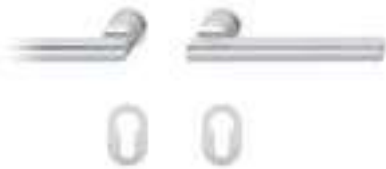

Edelstahl matt
Stainless steel
RF2431046



Schwarz matt
Black matte
RF2431047



Aluminium
RF2431045

Bern



Edelstahl matt
Stainless steel
RF2431026



Schwarz matt
Black matte
RF2431027



Aluminium
RF2431025

Highland



Edelstahl matt
Stainless steel
RF2431036



Schwarz matt
Black matte
RF2431037



Aluminium
RF2431035

Turn



Edelstahl matt
Stainless steel
RF2431016



Schwarz matt
Black matte
RF2431017



Aluminium
RF2431015

Kombinierbar mit „Highland“ Fenstergriffen!
Combinable with „Highland“ window handles!

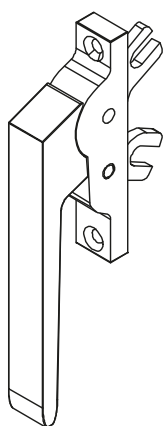
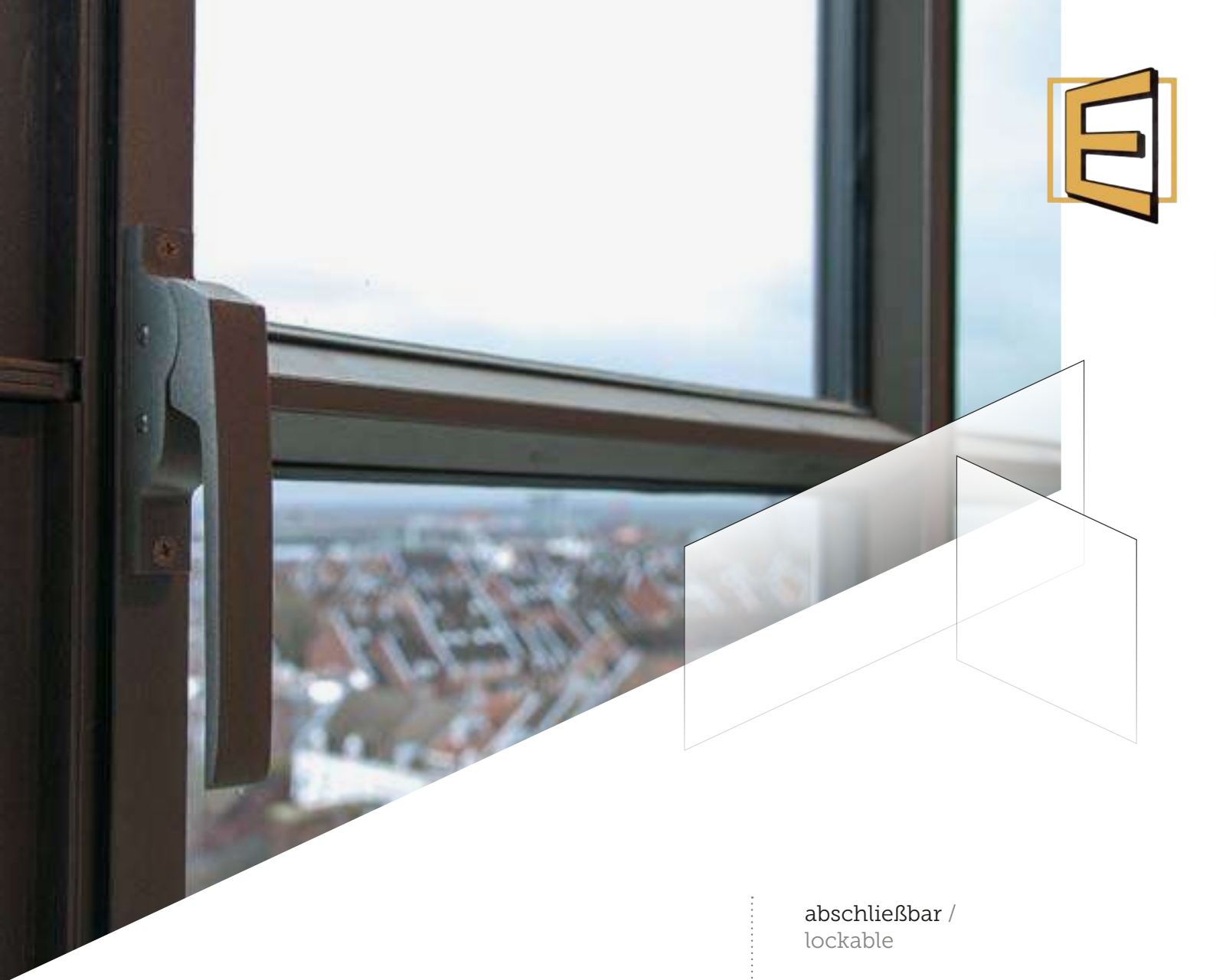

Aluminium
natur eloxiert (beschichtbar)
with a clear anodised finish
(coatable)
RF9130041-51N

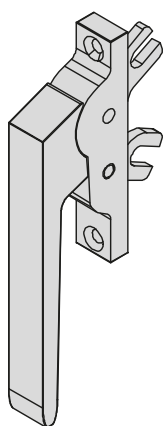

Schwarz matt
Matte black
RF9130045-51N

abschließbar /
lockable

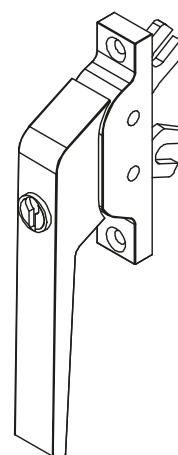

Aluminium
natur eloxiert (beschichtbar)
with a clear anodised finish
(coatable)
RF9130051-51N

Hebelgriff für Drehflügel und Stulpflügel
Lever handle for side-hung and double-vent windows

Standard-Fenstergriffe für
verdeckt liegende Beschläge
Standard window handles for concealed fittings

Optional für Dreh- und Stulpflügel
Optional for side-hung and double-vent windows



Edelstahl fein matt
Brushed stainless
steel matte
RX868400



Aluminium
RX868671

abschließbar /
lockable



Edelstahl fein matt
Brushed stainless
steel matte
RX805344



Aufliegende Beschläge
Overlaying fittings

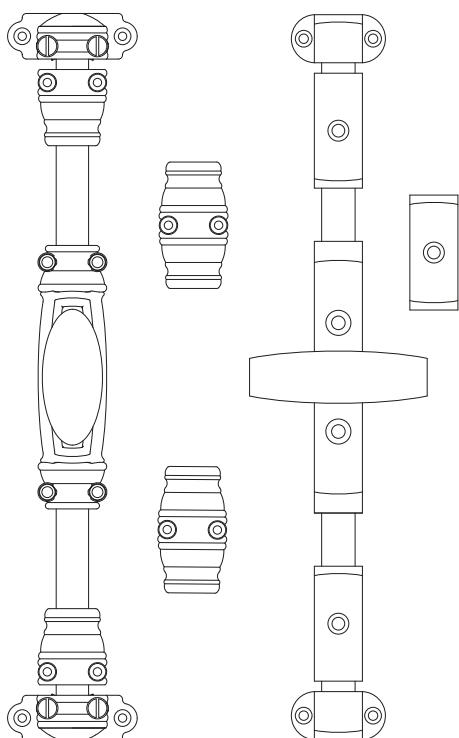





fineline 70



Filigranes Stahlsystem für Fenster und Türen Slim steel system for windows and doors

In jeder RAL-Farbe beschichtbare Bänder:
Hinges that can be coated in any RAL colour:



- Stahl, Edelstahl, Aluminium
Steel, stainless steel, aluminium
- Anschraub- und Anschweißbänder für Fenster
Screw-on and weld-on hinges for windows
- Verstellbare Rollentürbänder
(Ø 15 mm, max. 160 kg)
Adjustable barrel hinges
(ø 15 mm, max. 160 kg)

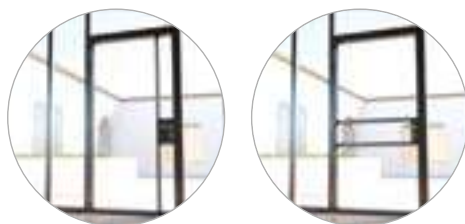

Schlosskästen für alle Designvarianten
Lock cases for all design variants

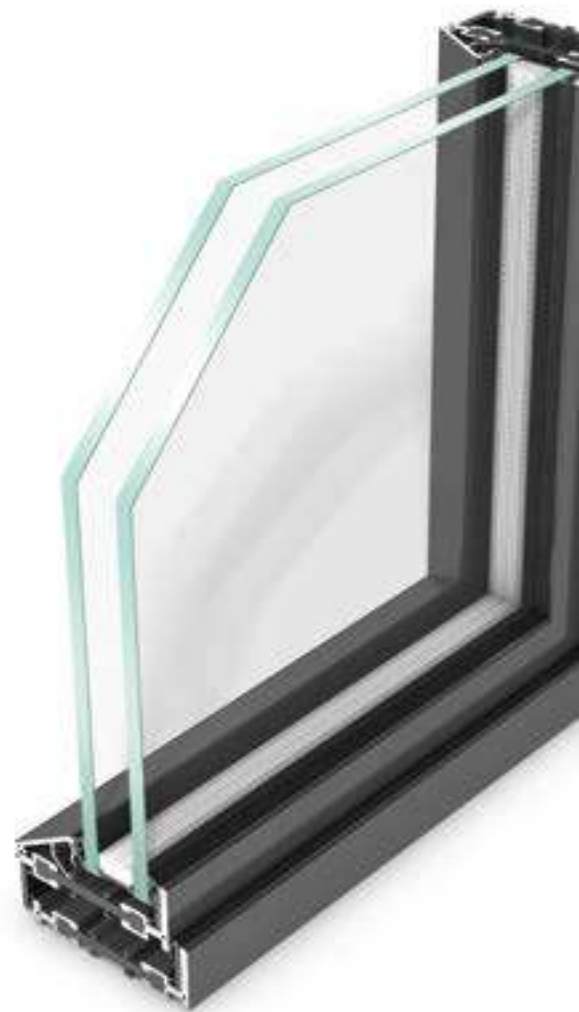

fineline 70W

Wärme gedämmte Stahlfenster
Thermally insulated steel windows



Extrem schmale Ansichtsbreite
Extremely slim face width

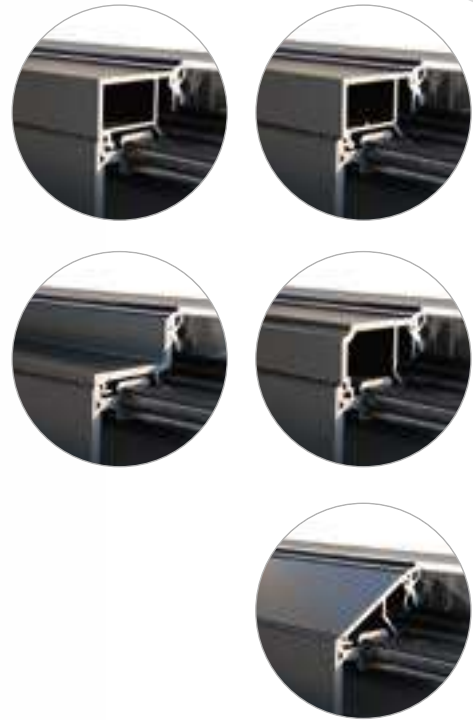
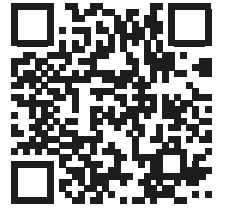

Glastleisten mit Ecken und Kanten
Glazing beads with angles and borders

fineline 70D

Wärmegeämmte Stahltüren
Thermally insulated steel doors

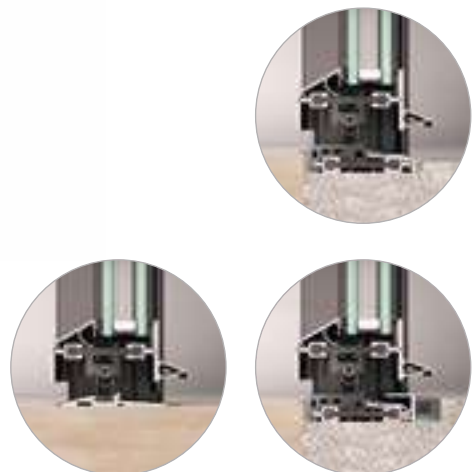

Schwellen für alle Gegebenheiten
Thresholds for all situations



Systemübersicht
System overview

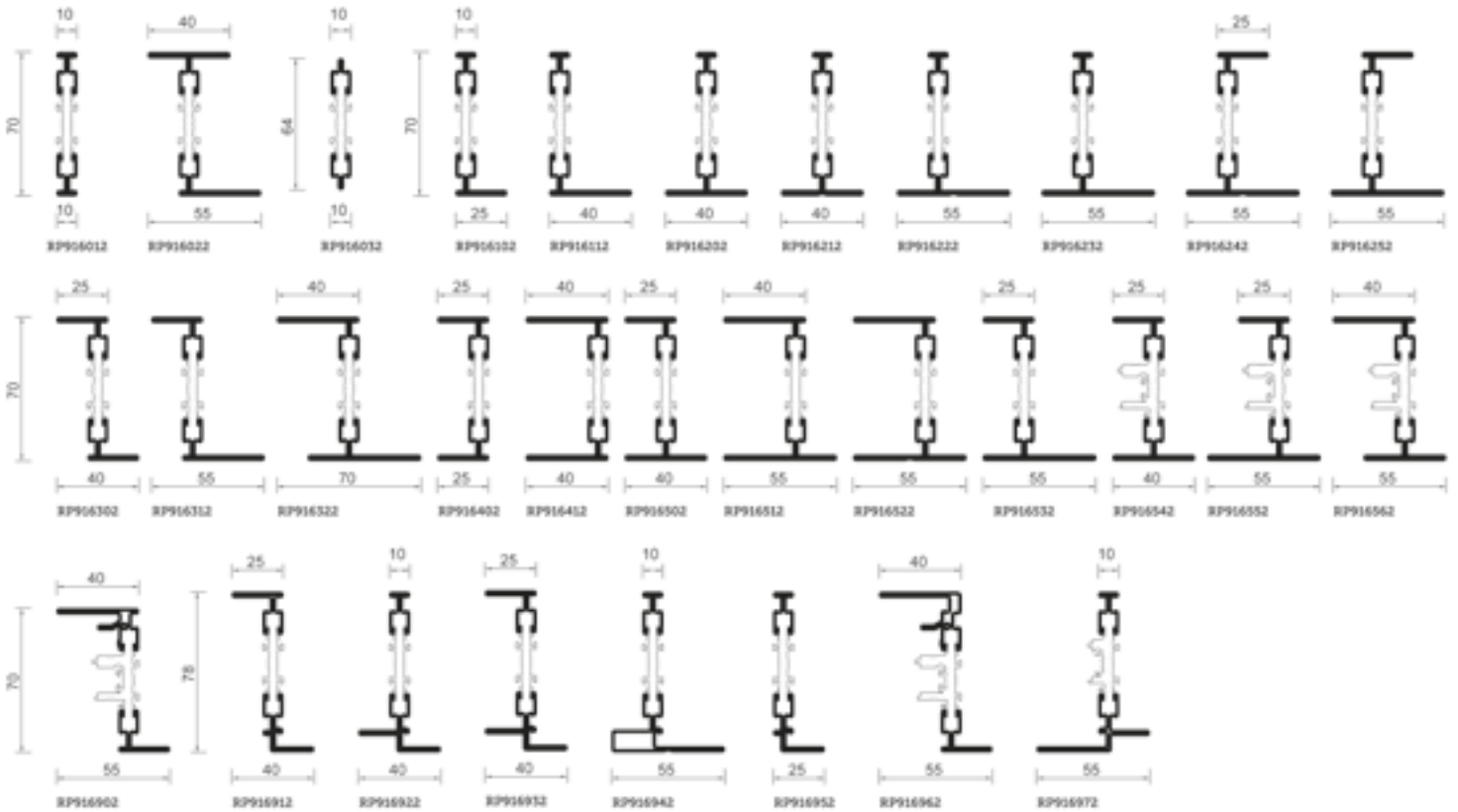

Glasleiste Standard
Standard glazing bead
(flächenbündig/flush surface)

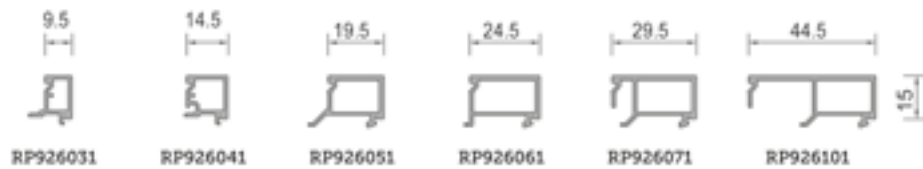
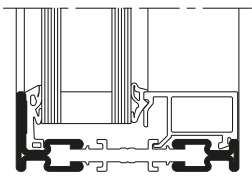

Glasleiste Kontur
Contoured glazing bead

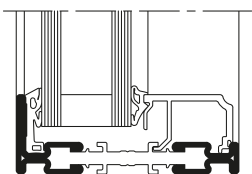



Glasleiste Versatz Offset glazing bead

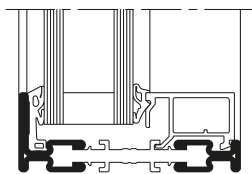

Glasleiste Winkel Angled glazing bead

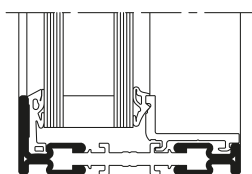

Glasleiste Schräg Inclined glazing bead

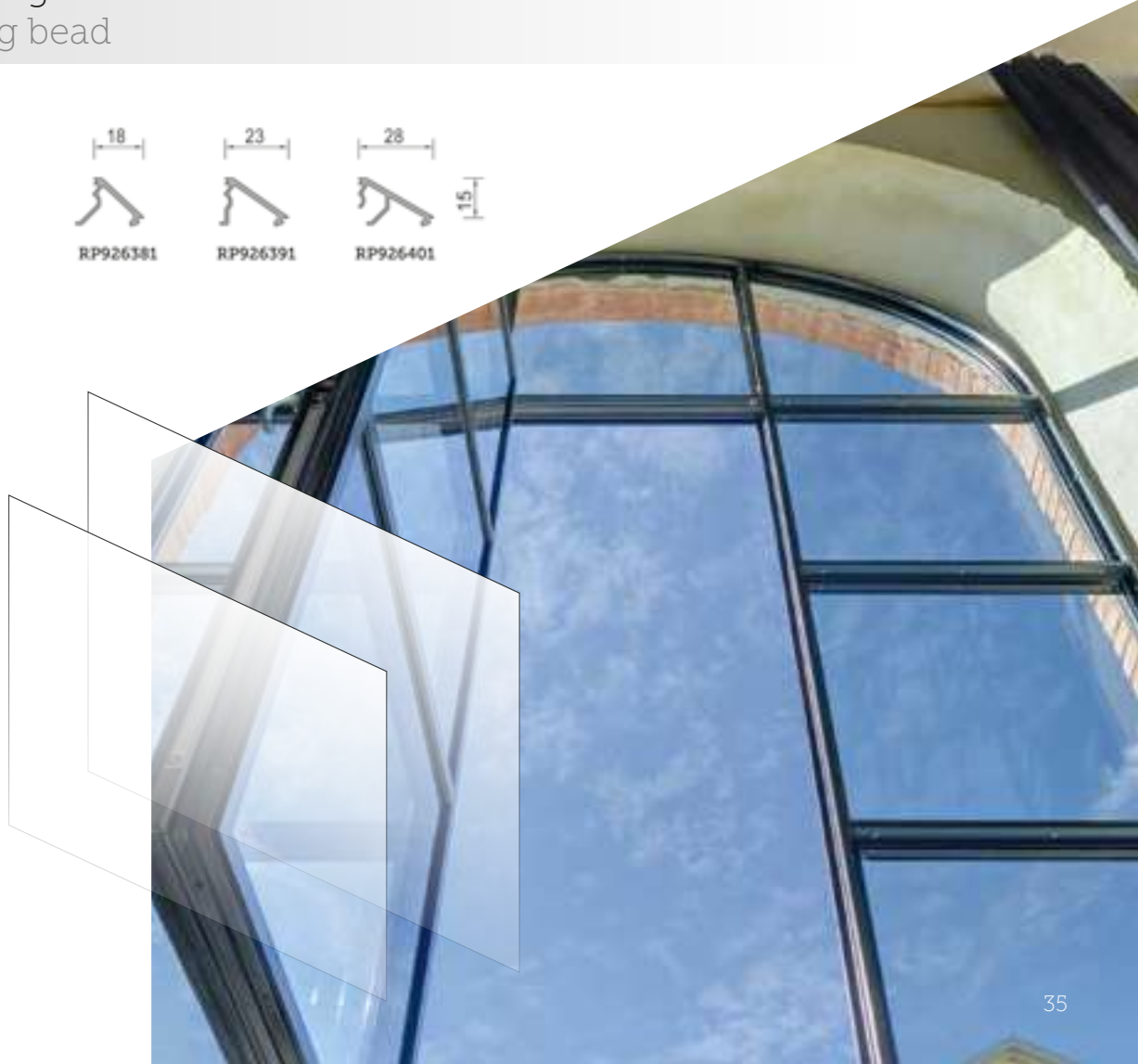
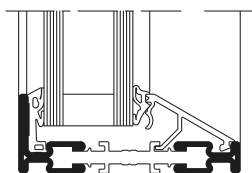



fineline 70W

Wärmegeämmte Stahlfenster
Thermally insulated steel windows

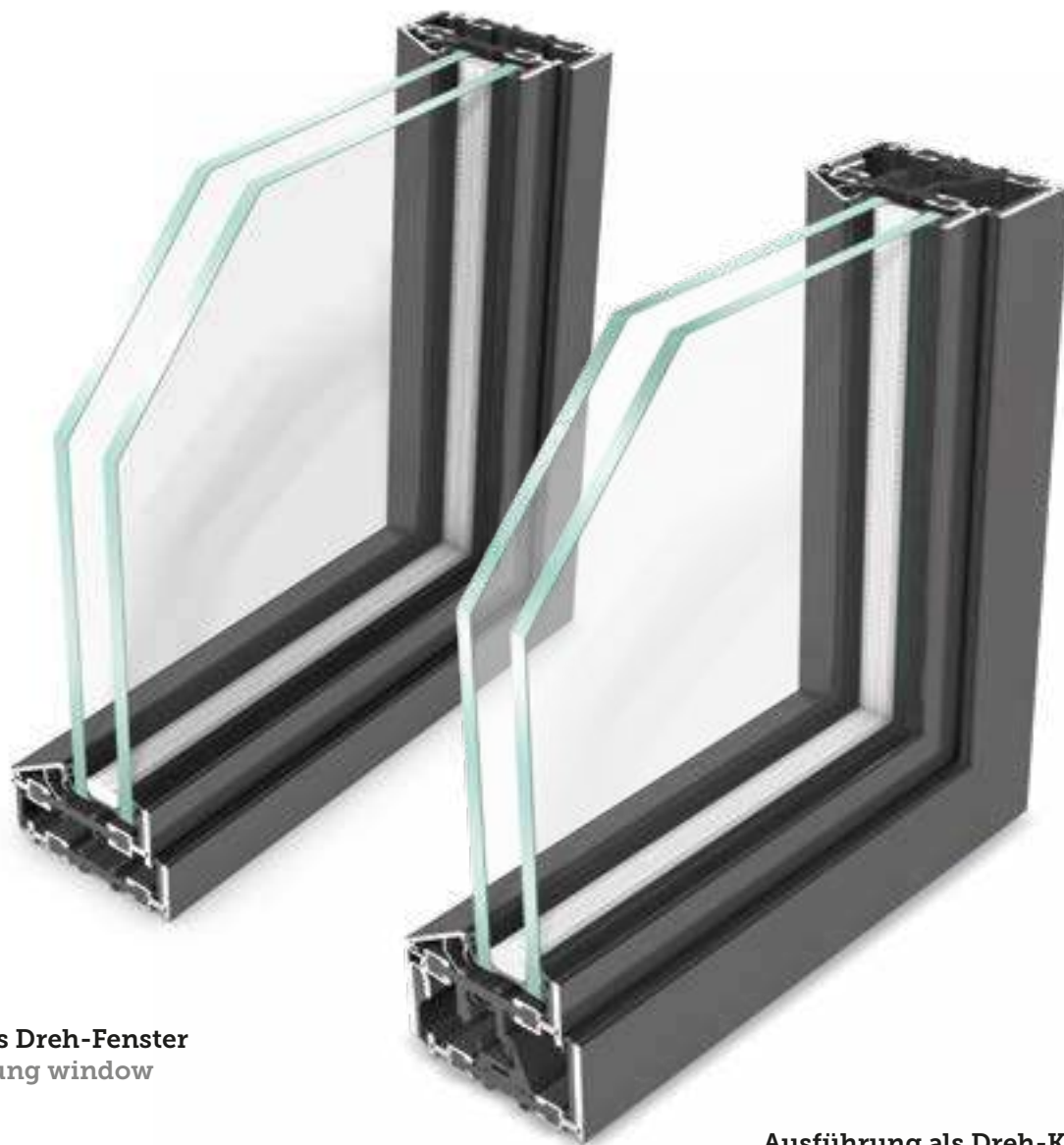

Ausführung als Dreh-Fenster
Model: Side-hung window

Ausführung als Dreh-Kipp-Fenster
Model: Turn/tilt window

Widerstandsfähigkeit bei Windlast Resistance under wind load	$\leq C5 / B5$
Luftdurchlässigkeit Air permeability	≤ 4
Schlagregendichtheit Watertightness	$\leq E900$
Stoßfestigkeit Impact strength	1
Wärmedurchgangskoeffizient Thermal transmittance	$U_f \geq 1,5 \text{ W/m}^2\text{K}$
Schallschutz Sound insulation	$\leq 50\text{dB}$
Dauerfunktionsprüfung Continuous performance test	≤ 4
Mechanisches Leistungsverhalten Mechanical performance	Anforderung der Klasse CW / TC 2 / A erfüllt Requirements of Class CW / TC 2 / A fulfilled
Mechanische Festigkeit Mechanical strength	4



Systemechnitte
Sections

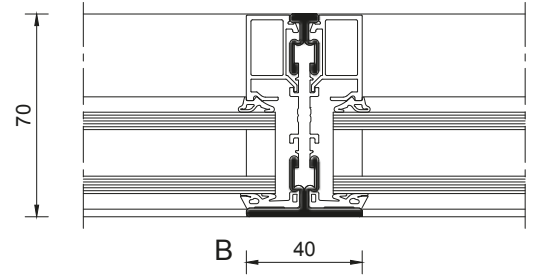
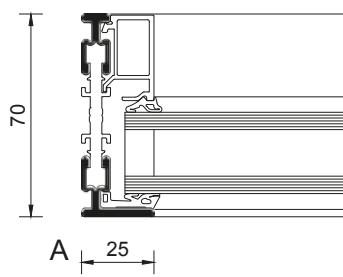
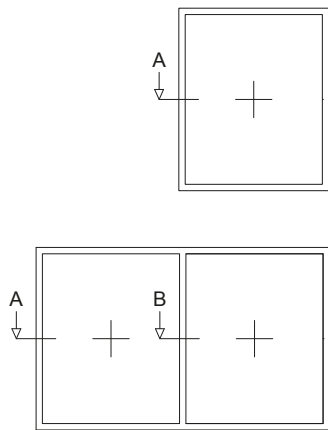

Fixverglasung
Fixed glazing

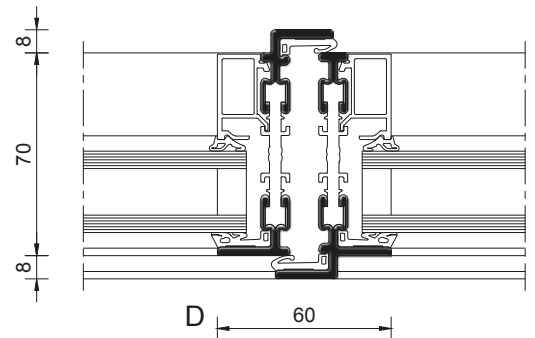
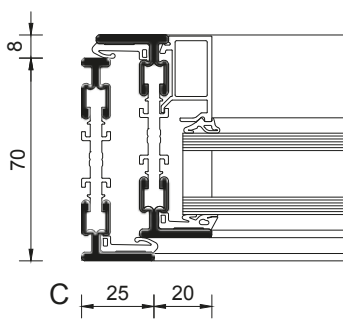
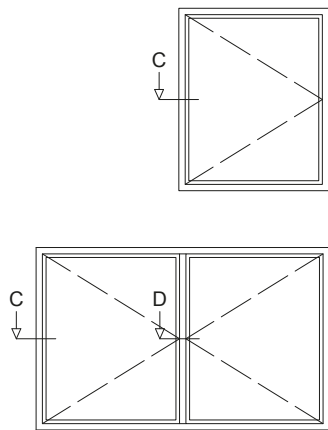

Flügel Standard
Standard sash

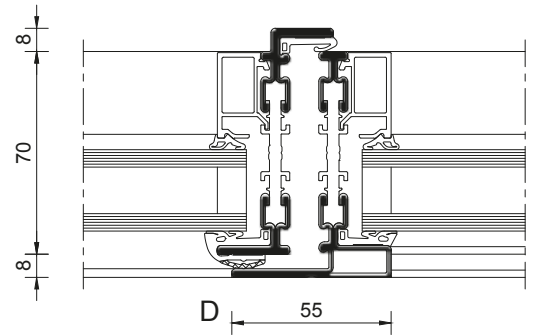
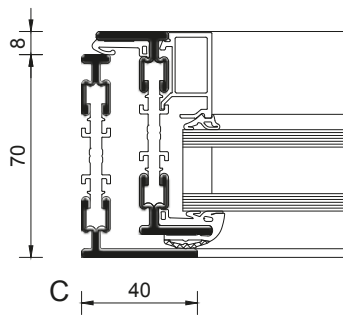

Flügel verdeckt
Concealed sash

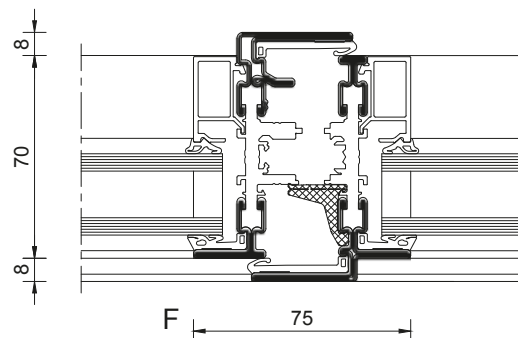
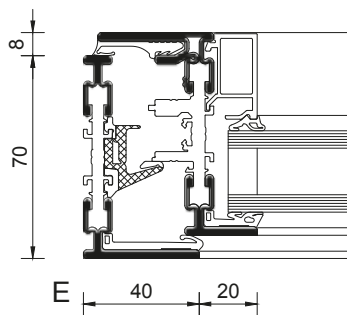
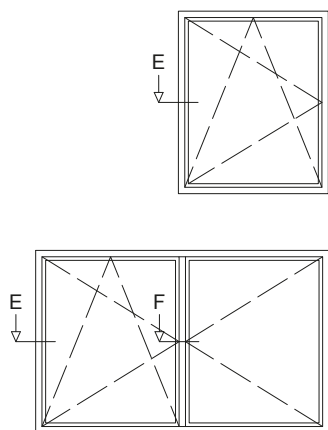

Flügel mit Euronut
Sash with Euro grooving

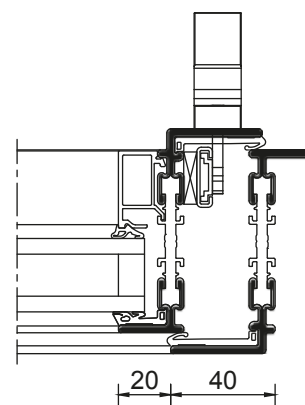
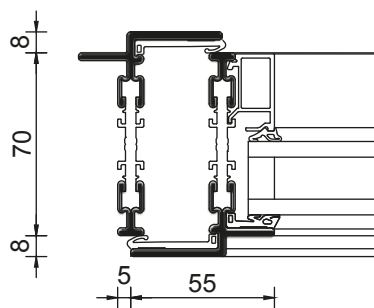
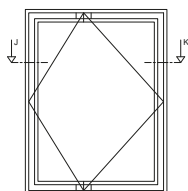

Flügel Wendefenster
Vertical pivot window sash









Systemechnitte
Sections

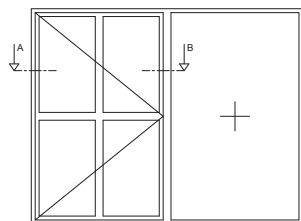

Schnitt A-B / Section A-B

Drehflügel Standard mit Treibriegelverschluss "Nostalgie"
Standard turning sash with shoot bolt lock "Nostalgia"

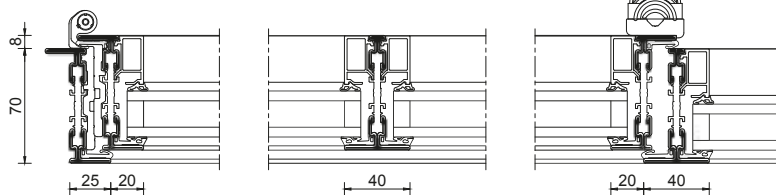

Schnitt B / Section B

Variante mit Treibriegelverschluss "klassisch"
Variant with shoot bolt lock "classic"

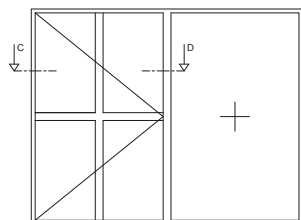
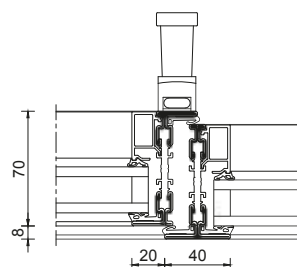

Schnitt C-D / Section C-D

Verdeckt liegender Flügel mit Drehbeschlag "Standard"
Concealed sash with turn fitting "standard"

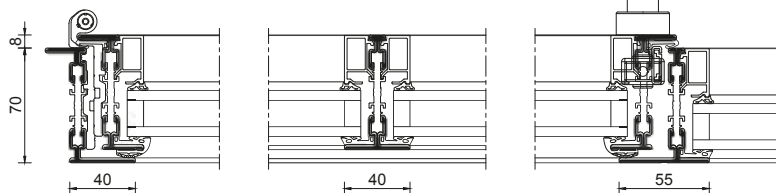

Schnitt D / Section D

Variante mit Hebelgriffbeschlag
Variant with lever handle fitting

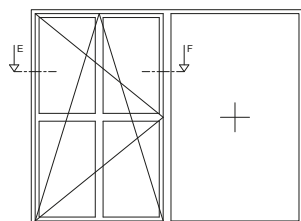
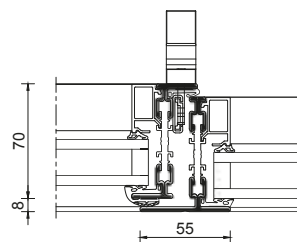

Schnitt E-F / Section E-F

Dreh-Kipp-Flügel mit verdeckt liegendem Euronutbeschlag
Turn-tilt sash with concealed Euro groove fitting

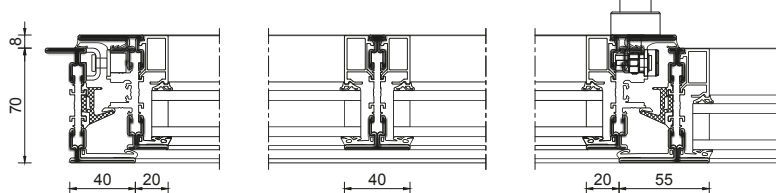

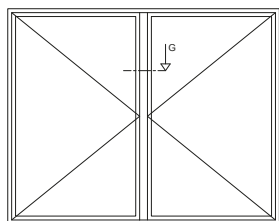

Schnitt G / Section G
 2-flügeliges Stulpfenster Standard Dreh / Dreh
 Double casement window standard turn / turn

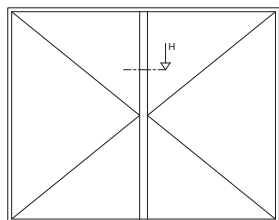
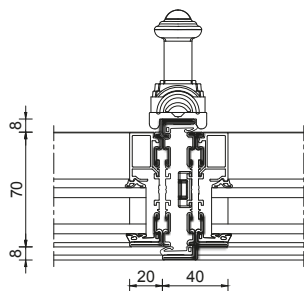

Schnitt H / Section H
 2-flügeliges Stulpfenster verdeckt Dreh / Dreh
 Double casement window concealed turn / turn

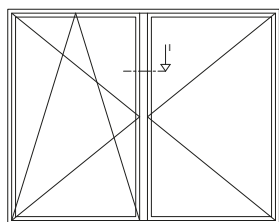
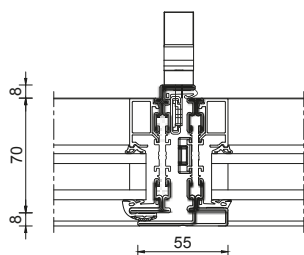

Schnitt I / Section I
 2-flügeliges Stulpfenster Dreh-Kipp / Dreh
 Double casement window turn-tilt / turn

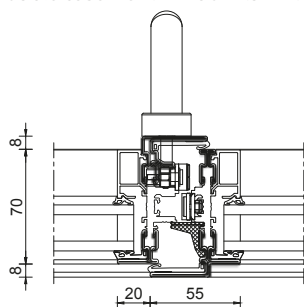

Weitere Beispiele aus der Objekttechnik
 Further examples from the project technology

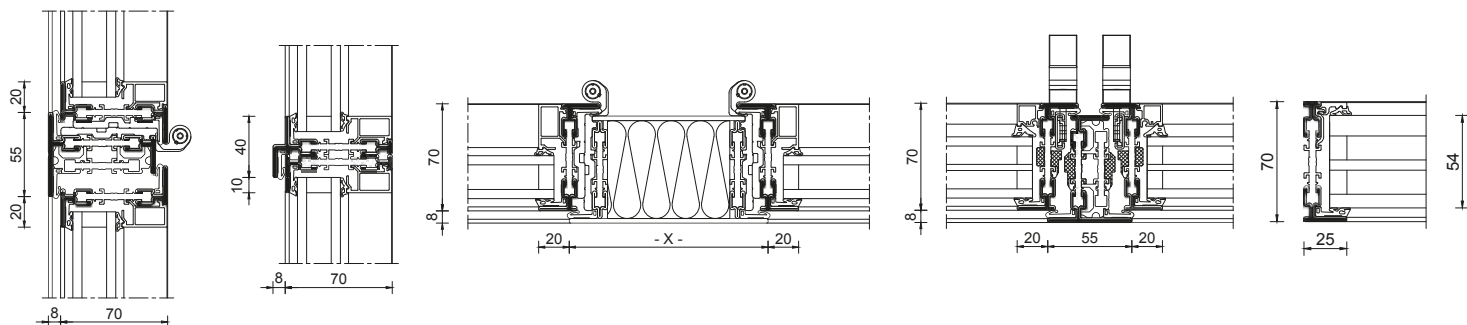



Bauanschlüsse fineline 70W Ju
 nctions fineline 70W

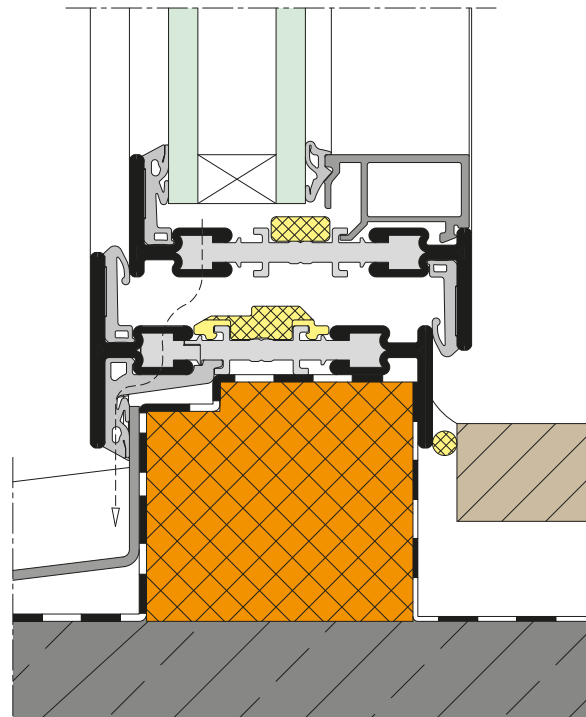
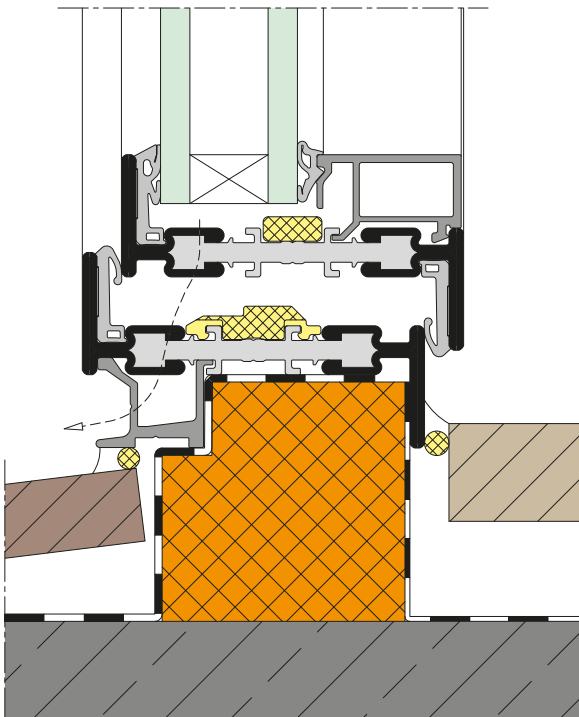
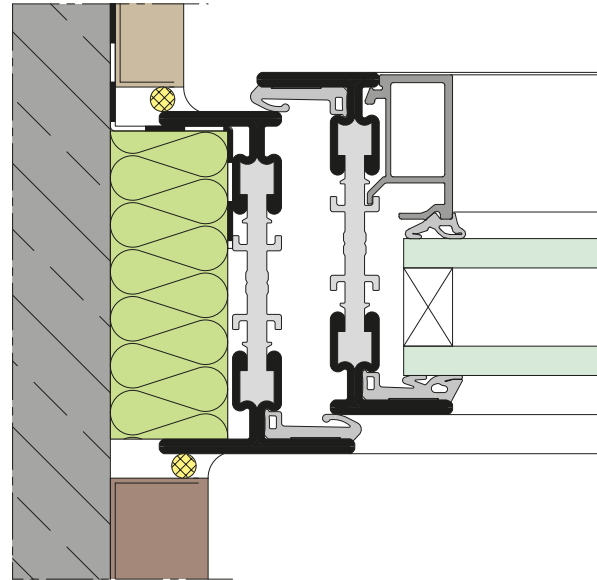
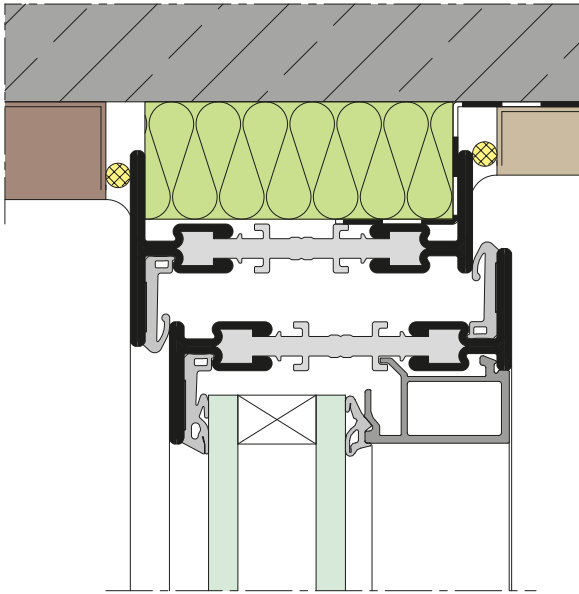



100%
verbunden
connected







fineline 70D

Wärmegeämmte Stahltüren
Thermally insulated steel doors



Widerstandsfähigkeit bei Windlast
Resistance under wind load

$\leq C3 / B3$

Luftdurchlässigkeit
Air permeability

≤ 4

Schlagregendichtheit
Watertightness

$\leq 5A$

Stoßfestigkeit
Impact strength

1

Wärmedurchgangskoeffizient
Thermal transmittance

$U_f \geq 1,7 \text{ W/m}^2\text{K}$



Systemechnitte
Sections

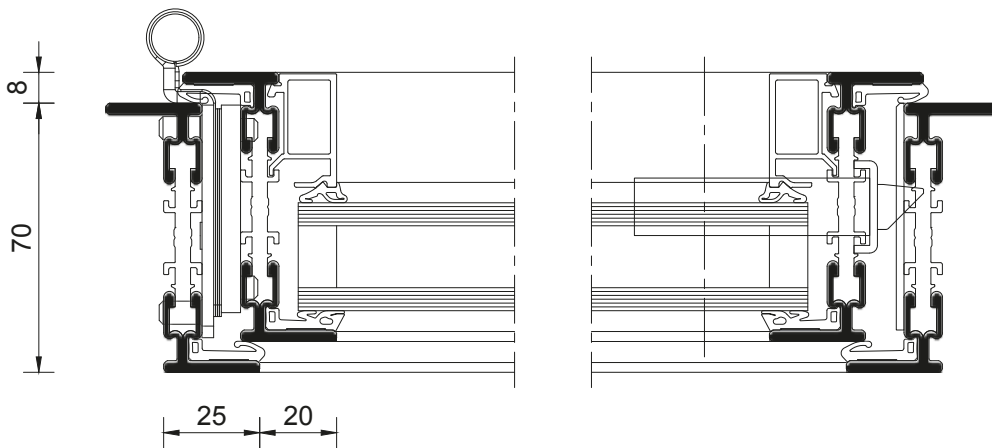
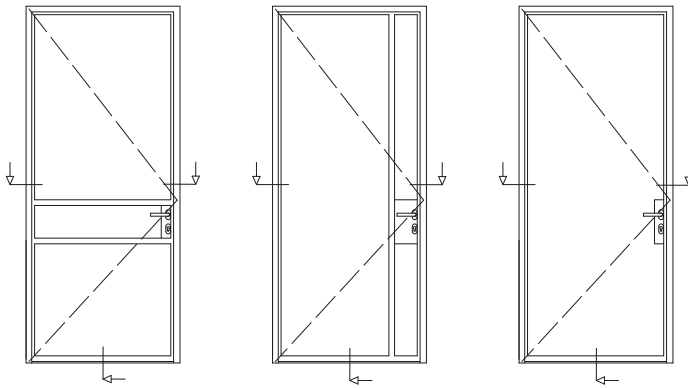

Tür
Door

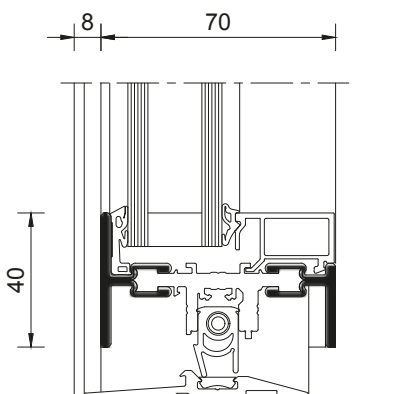

„Altbauschwelle“
„Old building threshold“

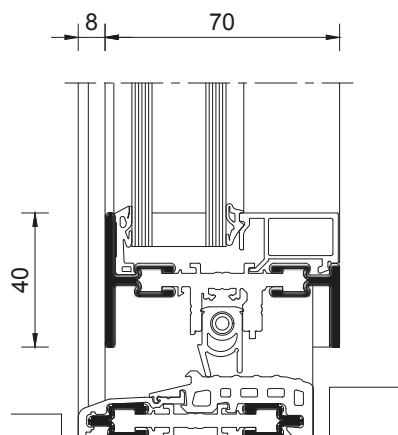

Normalschwelle
Normal treshold

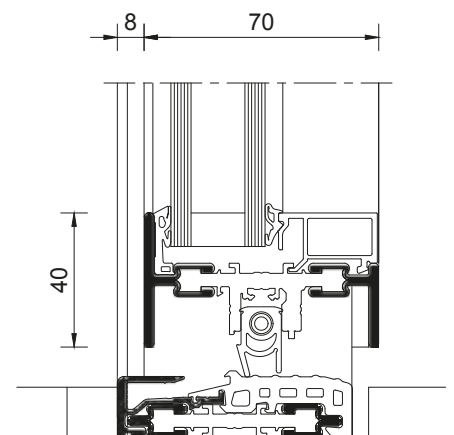

Nullschwelle
Zero treshold

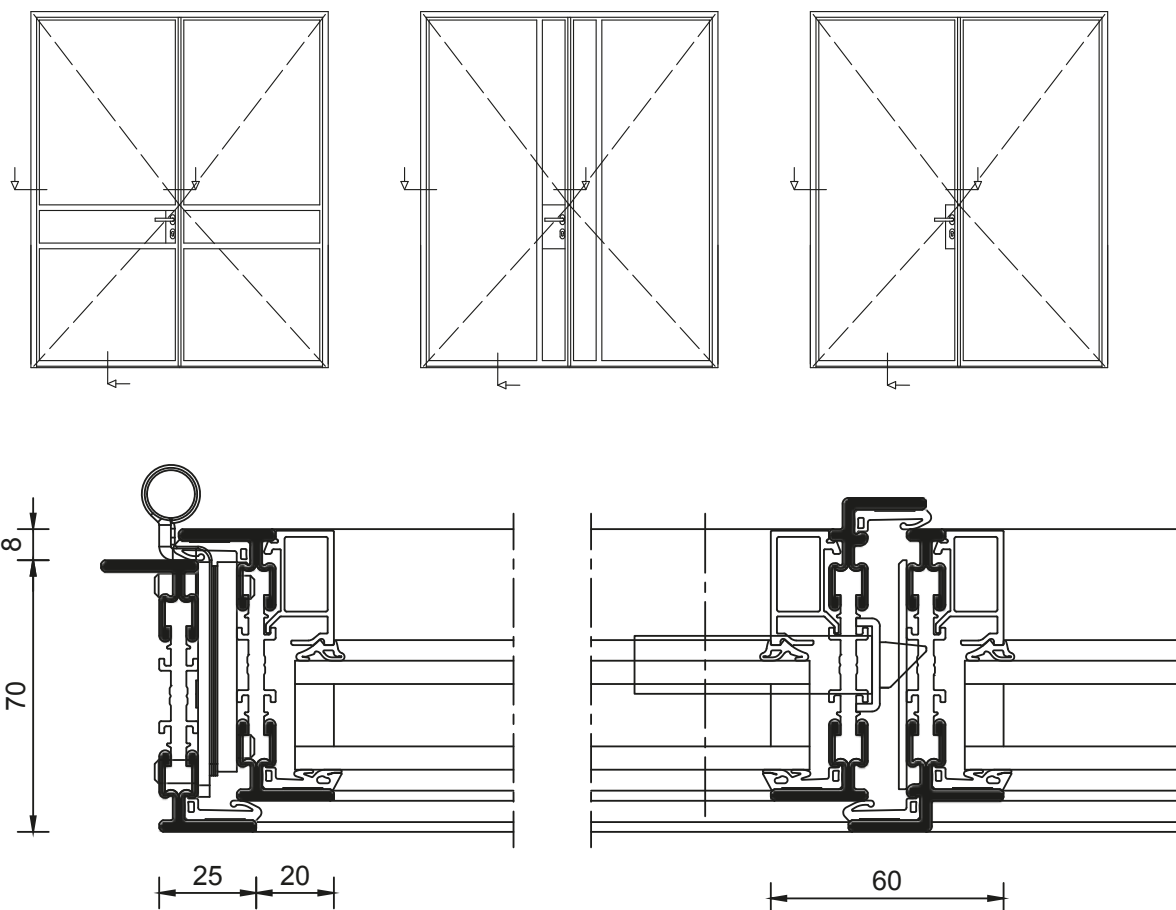

Tür 2-flügelig
Two-leaf door



fineline 50S

**Ungedämmtes, schmales Stahlsystem
für Schiebeelemente**
Non-insulated, slim steel system
for sliding elements



Widerstandsfähigkeit bei Windlast
Resistance under wind load $\leq C4$

Luftdurchlässigkeit
Air permeability ≤ 4

Schlagregendichtheit
Watertightness $\leq 7B$



Systemübersicht
System overview

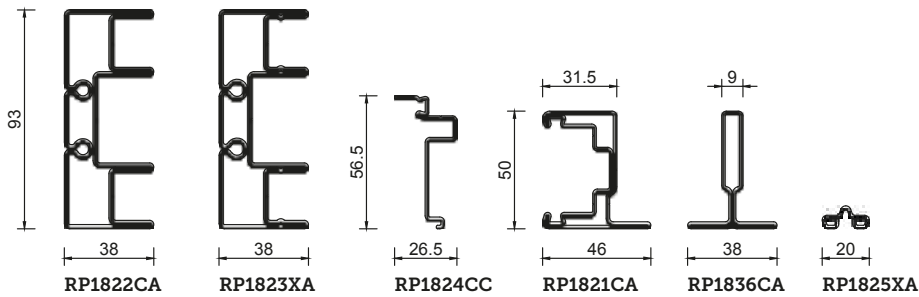

Glasleiste Standard
Standard glazing bead
(flächenbündig/flush surface)

Glasleiste Kontur
Contoured glazing bead

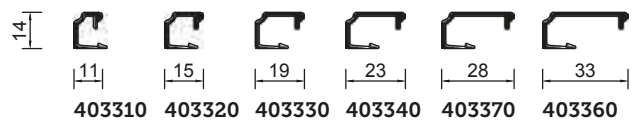
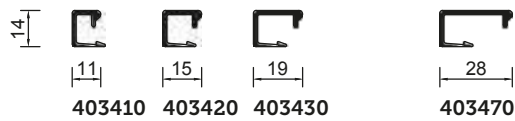



Beschläge
Fittings

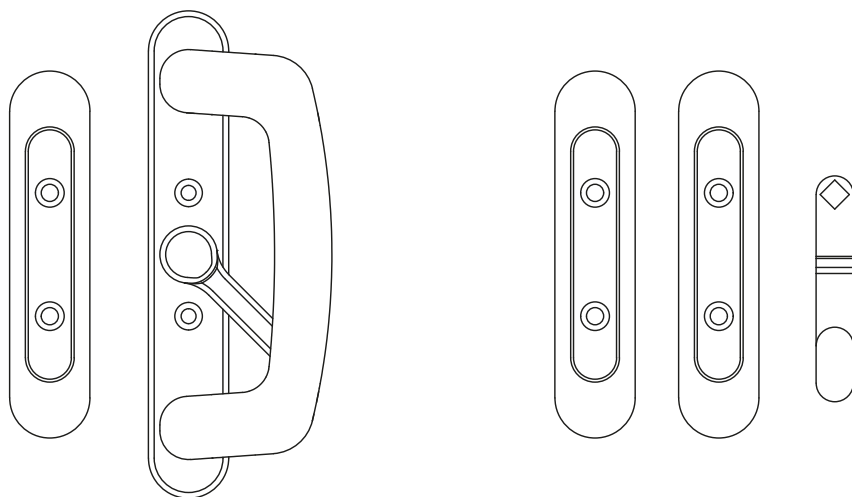



Systeme S
Schnitte

Schema A / Scheme A

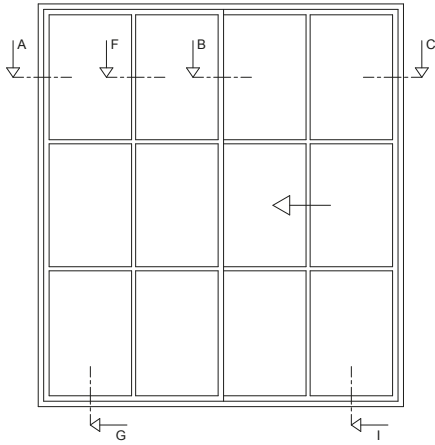

Schema C / Scheme C

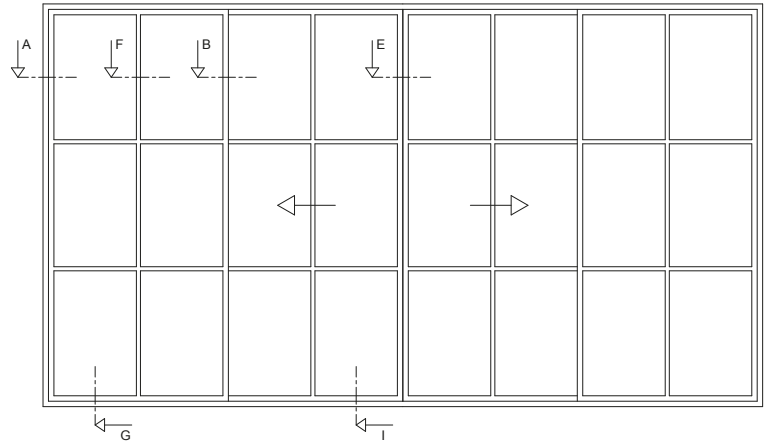

Schema D / Scheme D

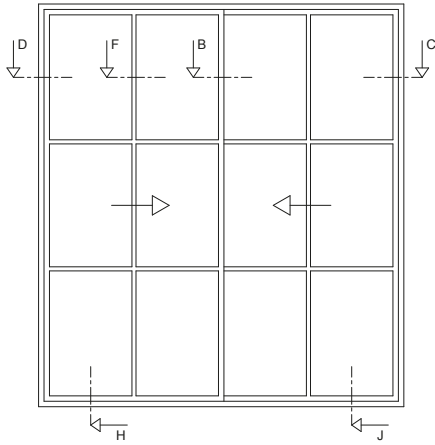

Schema F / Scheme F

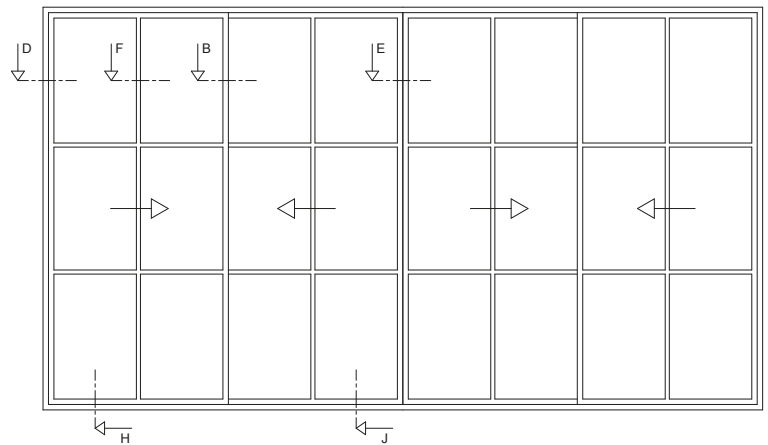



Schnitt C / Section C

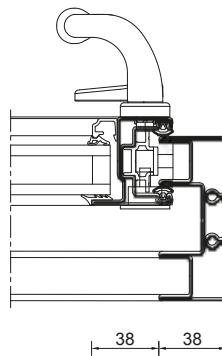

Schnitt A / Section A

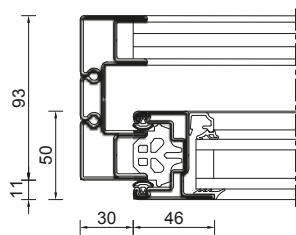

Schnitt B / Section B

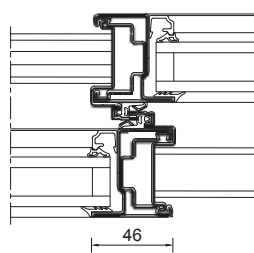

Schnitt E / Section E

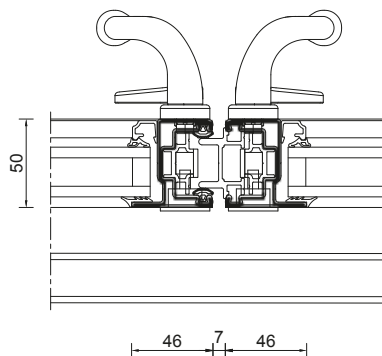

Schnitt D / Section D

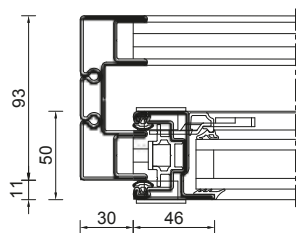

Schnitt F / Section F

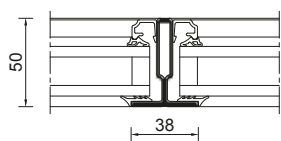

Schnitt G / Section G

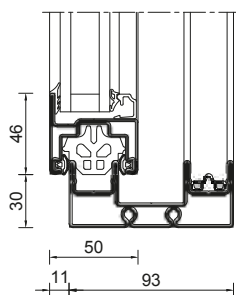

Schnitt H / Section H

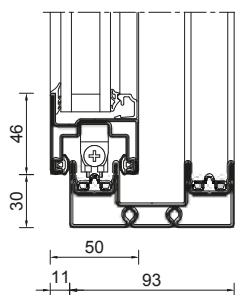

Schnitt I / Section I

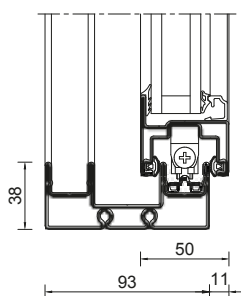

Schnitt J / Section J

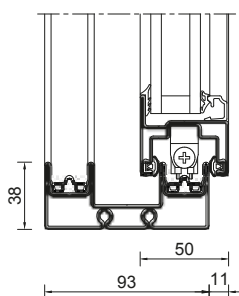



fineline 60

**Ungedämmtes, filigranes Stahlsystem
für Fenster, Türen und Trennwände**
Non-insulated, filigree steel system
for windows, doors and partitions



Widerstandsfähigkeit bei Windlast
Resistance under wind load $\leq C3$

Luftdurchlässigkeit
Air permeability ≤ 4

Schlagregendichtheit
Watertightness $\leq 7B$

Schallschutz
Sound insulation $\geq 44 \text{ dB}$



Systemübersicht
System overview

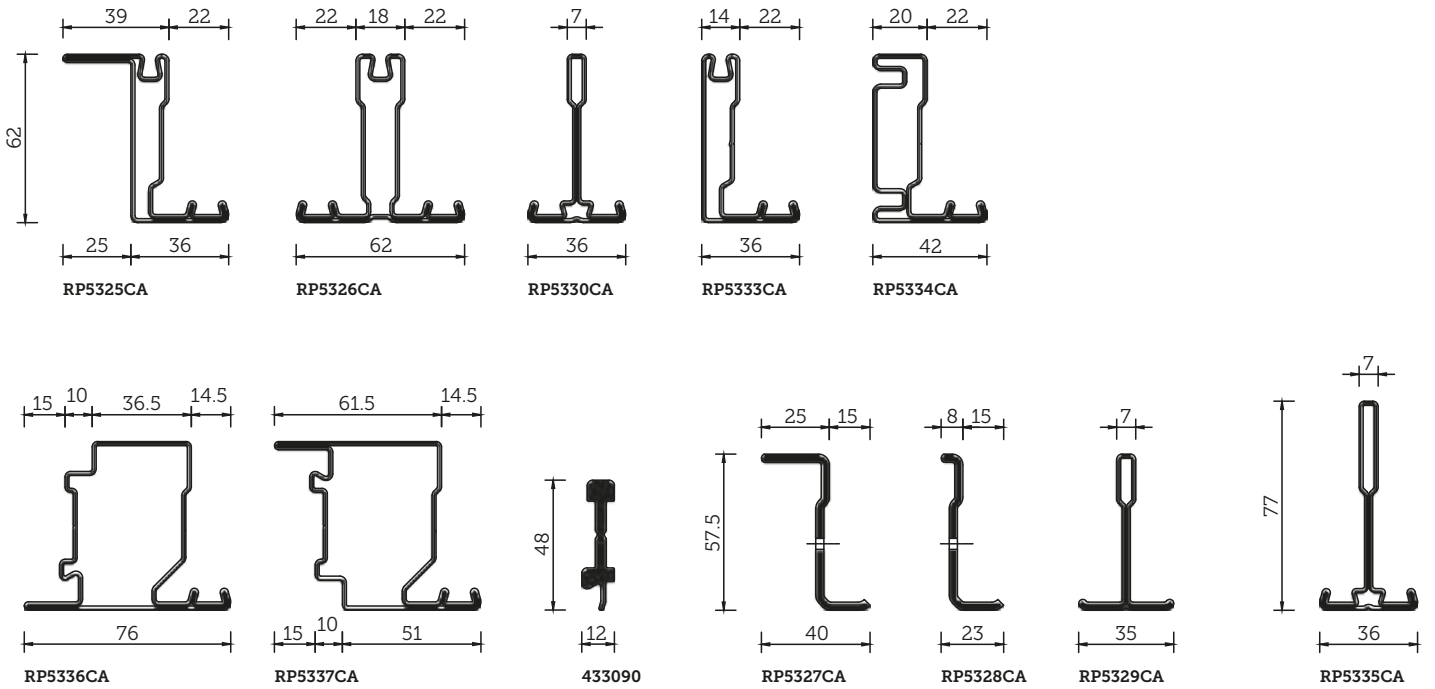

Glasleiste Standard
Standard glazing bead
(flächenbündig/flush surface)

Glasleiste Kontur
Contoured glazing bead

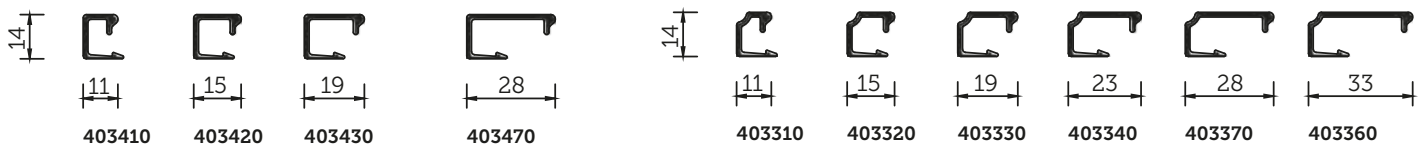



Aufliegende Beschläge Overlaying fittings

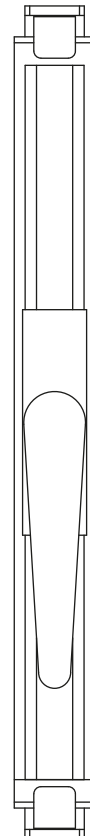
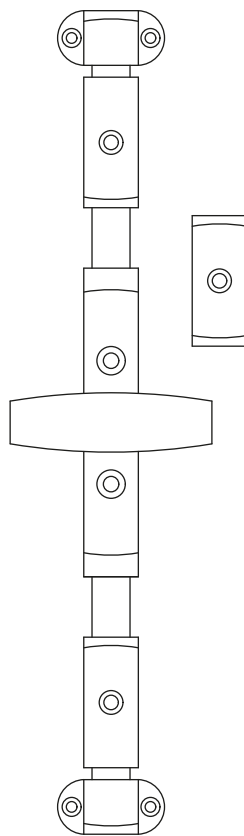
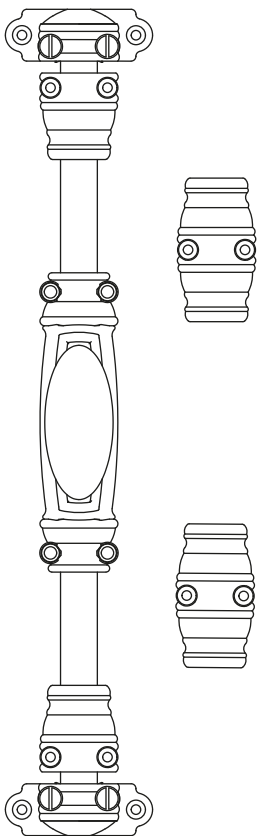



Systemschnitte
Sections

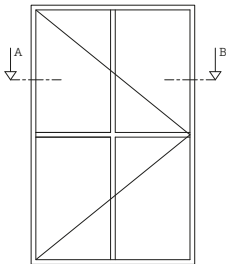

Schnitt A-B / Section A-B

Drehflügel Standard mit Treibriegelverschluss "Nostalgie"
Standard turning sash with shoot bolt lock "Nostalgia"

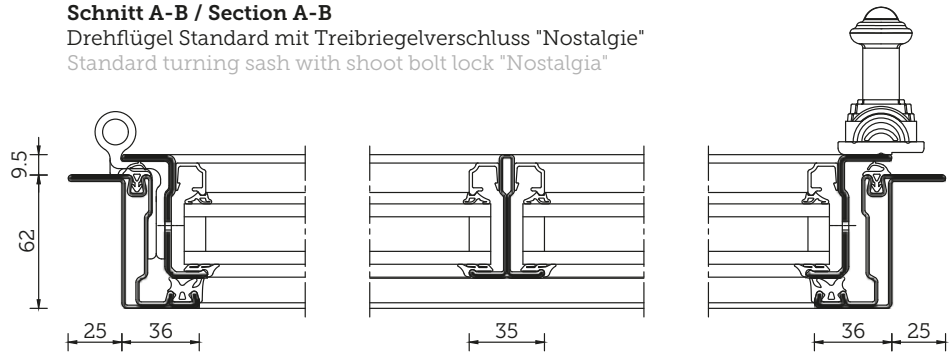

Schnitt B / Section B

Variante mit Treibriegelverschluss "klassisch"
Variant with shoot bolt lock "classic"

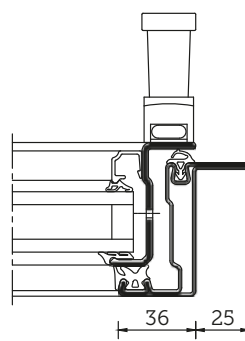

Schnitt B / Section B

Variante mit Treibriegelverschluss "modern"
Variant with shoot bolt lock "modern"

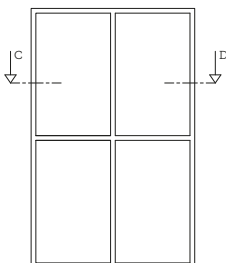
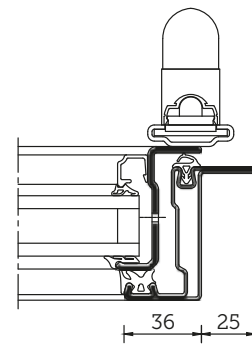

Schnitt C-D / Section C-D

Festverglasung
Fixed glazing

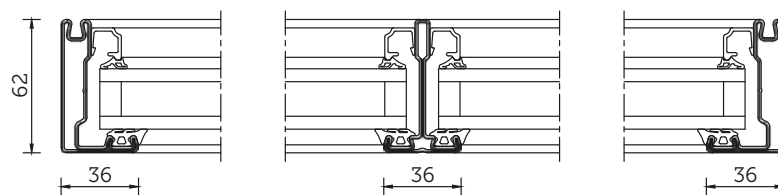

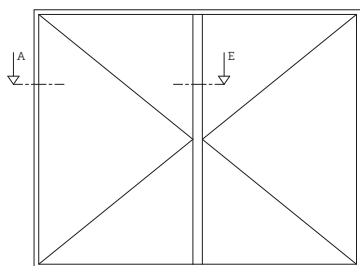

Schnitt A-E / Section A-E
2-flügeliges Stulpfenster Dreh / Dreh
Double casement window turn / turn

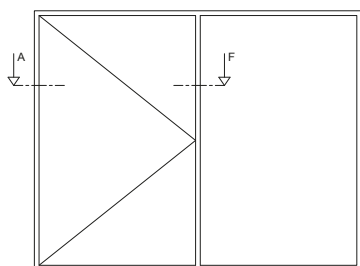
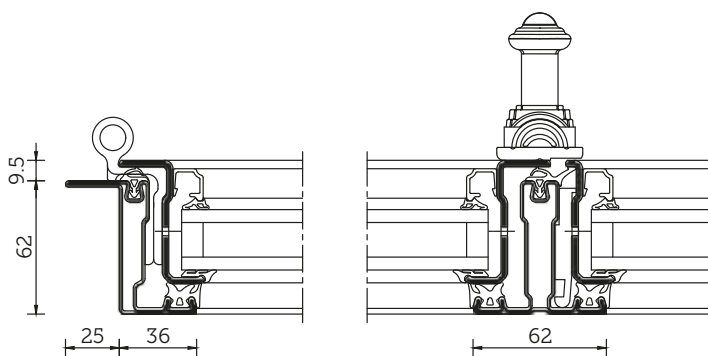

Schnitt A-F / Section A-F
Drehflügel mit festem Seitenteil
Turning sash with fixed side panel

